

SA SELECTORIZED SERIES

SA044 - BICEPS/TRICEPS



PRODUCT OVERVIEW

The SA044 is a dual-function selectorized strength machine designed for effective training of both the biceps and triceps. Featuring a dual-angle extended handle design and a 68° range of motion, it ensures a comfortable grip that naturally adapts to forearm rotation, maintaining a neutral wrist position for more efficient and ergonomic arm movement. The arm settings offer two adjustment positions for biceps curls and three for triceps extensions, accommodating various forearm lengths and reducing strain on the wrists.

Ergonomically contoured arm and chest pads provide stable support regardless of shoulder width, helping users maintain proper posture and maximize muscle activation. The six-position adjustable seat, paired with a front footrest, stabilizes the body and allows users of all heights to align their movement path precisely with the machine's pivot axis, ensuring accurate and effective muscle engagement.

SPECIFICATIONS & KEY FEATURES

Specifications

Dimension:	1379*1146*1566mm
Total Weight:	215kg
Weight Stack:	100kg
Max Weight Stack:	125kg

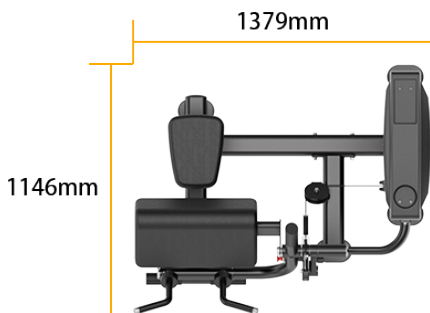
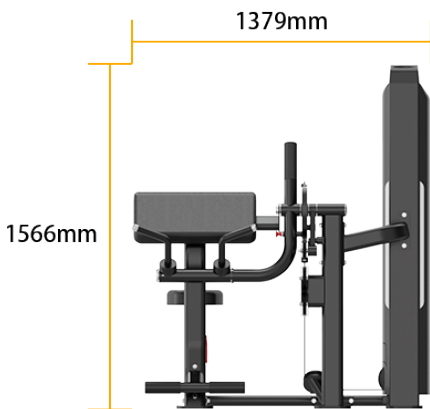

Product Features

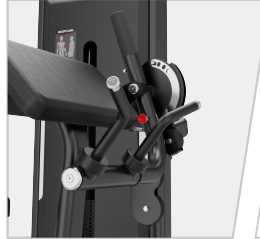

Dual-Function Design

Supports both biceps curl and triceps extension exercises, enabling comprehensive development of arm strength.



Extended Dual-Angle Handle Design

Offers a natural, comfortable grip that self-adjusts to forearm rotation and keeps the wrist neutral throughout each movement.



2+3 Position Arm Adjustment System

Supports users with different forearm lengths, minimizing wrist stress for safer, more ergonomic training.

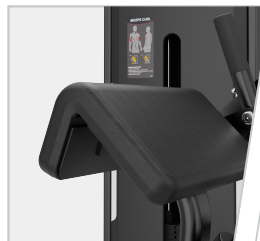

Ergonomic Arm and Chest Pads

Provide stable, body-aligned support for correct posture and enhanced comfort during exercise.

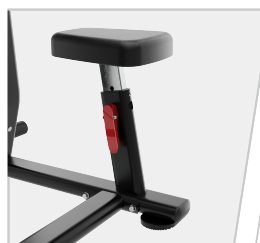

Six-Position Adjustable Seat

Adapts to users of various heights, ensuring optimal training alignment and performance.